

Frischwasserspeicher
Fresh water storage tank
Ballon d'eau fraiche
Accumulatori d'acqua dolce
JH 600 – 2000

DIN

EN 12897

EnEV 730.02

ErP 812/2013

ErP 814/2013



0808-5401

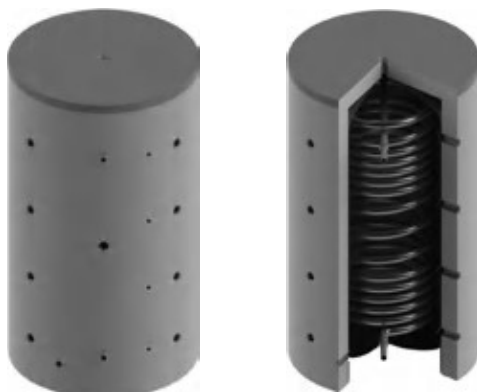

Bauart

Design | Structure | Struttura

Die Speicher werden aus hochwertigem Stahl nach EN 10025:2019 gefertigt.

Die Wärmetauscher bestehen aus Edelstahl V4A. Die Speicher sind innen unbehandelt.

EN The storage tanks are made from high quality steel in accordance with EN 10025:2019.

The heat exchanger is made from stainless steel (V4A).

The tanks are not treated on the inside.

FR Les ballons sont fabriqués en acier de grande qualité, selon la norme EN 10025:2019.

Les échangeurs de chaleur sont en acier inoxydable au molybdène.

L'intérieur des ballons n'est pas traité.

IT Gli accumulatori sono realizzati in acciaio pregiato secondo la norma EN 10025:2019.

Lo scambiatore di calore è realizzato in acciaio inossidabile V4A.

L'interno degli accumulatori non è trattato.

Betriebsdruck / Prüfdruck
 Operating pressure / test pressure | Pression de service / Pression test |
 Pressione d'esercizio / Pressione di collaudo

3 bar / 4.5 bar

Einsatzgebiet
 Application | Application | Applicazione

18°C – 95°C



Schutz vor Korrosion

Anti-corrosion protection | Protection contre la corrosion | Protezione anticorrosiva

Innen sind die Speicher unbehandelt. Aussen sind die Speicher grundiert.
Der Wellrohrwärmetauscher ist aus hochwertigem Edelstahl V4A gefertigt.

EN The storage tanks are untreated on the interior. Tanks are primed on the outside. The corrugated pipe heat exchanger is made of high-quality stainless steel V4A.

FR À l'intérieur, les réservoirs ne sont pas traités. A l'extérieur, les réservoirs sont apprêtés. L'échangeur thermique est fabriqué en acier inoxydable V4A haut de gamme.

IT L'interno degli accumulatori non è trattato. Gli accumulatori sono primerizzati all'esterno. Lo scambiatore di calore a tubi corrugati è realizzato in pregiato acciaio inossidabile V4A.

Wärmetauscher

Heat exchanger | Échangeur de chaleur | Scambiatore di calore

Brauchwasser: Ein eingeschweisstes Wellrohr aus Edelstahl V4A

EN Service water: A welded corrugated tube from stainless steel V4A.

FR Eau sanitaire: Un tube ondulé soudé en Acier inoxydable V4A au molybdène.

IT Acqua per uso domestico: Un tubo ondulato saldato in acciaio inossidabile V4A.

Betriebsdruck / Prüfdruck Operating pressure / test pressure Pression de service / Pression test Pressione d'esercizio / Pressione di collaudo	6 bar / 12 bar
Einsatzgebiet Application Application Applicazione	max. 95°C Cl ≤ 70 mg/l ≤ 12°dH ≤ 21°fH

Isolierung

Insulation | Isolation | Isolamento

TopShell

Isolierung aus Hightech Faservlies. Skaimantel mit Reissverschluss, inklusive Rosetten und Abdeckhaube.
Brandschutzklasse B2. Silber. Lose geliefert.

Variante

Isolierung aus Hightech Faservlies. PS-Mantel und Hakenleiste, inklusive Rosetten und Abdeckhaube.
Brandschutzklasse B2. Farbe Silber.

EN TopShell

Insulation made of high-tech fibre fleece. Skai jacket with zip, including cover plates and hood. Fire-resistance rating B2. Silver. Supplied loose.

FR TopShell

Isolation en tissu fibreux high-tech Enveloppe en skai avec fermeture à glissière, y compris rosettes et capot. Classe allemande de protection incendie B2. Argent. Livrée non montée.

IT TopShell

Isolamento in tessuto non tessuto high-tech. Mantello in skai pre-assemblato con cerniera, dotato di rosette e calotta di copertura. Classe di resistenza antincendio B2. Argento. Consegna sfusa.

Alternative

Insulation made of high-tech fibre fleece. PS jacket and hook rack, including cover plates and hood. Fire-resistance rating B2. Silver.

Alternative

Isolation en tissu fibreux high-tech Enveloppe en PS équipée d'un support à crochets préinstallé, y compris rosettes et capot. Classe allemande de protection incendie B2. Couleur argent.

Alternativa

Isolamento in tessuto non tessuto high-tech. Mantello in PS e barra con ganci, rosette e calotta di copertura incluse. Classe di resistenza antincendio B2. Colore argento.

TopShell
B2; $\lambda = 0.038 \text{ W/(mK)}$

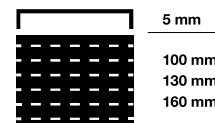

Frischwasserspeicher
Fresh water storage tank
Ballon d'eau fraiche
Accumulatori d'acqua dolce
JH 600 – 2000

Verwendung Usage Utilisation Uso		600	800	1000	1250	1500	2000		
TopShell 100	Wärmeverlust Heat losses Pertesthermiques Perdita di calore	kWh/24h	2.89	3.12	3.38	3.82	-	-	
		W	121	130	141	160	-	-	
	ErP-Label ErP class Classe ErP Classe ErP		C	C	C	C	-	-	
	CH SIA 384/1 Ta ≤ 90°C		•	•	•	•	X	X	
	EU Nr. 814/2013 (EU)		•	•	•	•	X	•	
	A \downarrow [mm]		1700	1740	2090	2060	2200	2420	
	C Ø [mm]		900	990	990	1150	1200	1300	
	Art. Nr. 300113... Part no. Réf. Art.n.		0601	0801	1001	1251	1501*	2001	
	TopShell 130	Wärmeverlust Heat losses Pertesthermiques Perdita di calore	kWh/24h	-	-	-	-	4.00	-
			W					167	
ErP-Label ErP class Classe ErP Classe ErP			-	-	-	-	C	-	
CH SIA 384/1 Ta ≤ 90°C			•	•	•	•	•	X	
EU Nr. 814/2013 (EU)			•	•	•	•	•	•	
A \downarrow [mm]			1730	1770	2120	2090	2230	2450	
C Ø [mm]			960	1050	1050	1210	1260	1360	
Art. Nr. 300113... Part no. Réf. Art.n.			0602*	0802*	1002*	1252*	1502	2002*	
TopShell 160		Wärmeverlust Heat losses Pertesthermiques Perdita di calore	kWh/24h	-	-	-	-	-	-
			W	-	-	-	-	-	-
	ErP-Label ErP class Classe ErP Classe ErP		-	-	-	-	-	-	
	CH SIA 384/1 Ta ≤ 90°C		•	•	•	•	•	•	
	EU Nr. 814/2013 (EU)		•	•	•	•	•	•	
	A \downarrow [mm]		1760	1800	2150	2120	2260	2480	
	C Ø [mm]		1020	1110	1110	1270	1320	1420	
	Art. Nr. 300113... Part no. Réf. Art.n.		0603*	0803*	1003*	1253*	1503*	2003	

Ta = Auslegungstemperatur

Ta = dimensioning temperature | Ta = température de conception | Ta = temperatura di progetto

* Keine Lagerware.

Not in stock. | Marchandise non stockée. | Merce non a magazzino.

Nicht zugelassen | None approved | Non agréée | Non omologato

Zugelassen (Empfohlene Isolierung)
Approved (Recommended insulation) | Agréée (Isolation recommandée) | Omologato (Isolamento consigliato)

Zugelassen (oberhalb Mindestanforderung)
Approved (Exceeds minimum requirements) | Agréée (Supérieure aux exigences minimales requises) | Omologato (Requisito minimo superiore)

Frischwasserspeicher
Fresh water storage tank
Ballon d'eau fraiche
Accumulatori d'acqua dolce
JH 600 – 2000

Typ JH		600	800	1000	1250	1500	2000
Bruttoinhalt Gross capacity Contenance brute Contenuto lordo	l	560	718	887	1266	1500	2015
Nettoinhalt Net capacity Contenance nette Contenuto netto	l	532	687	856	1215	1449	1964
Höhe ohne Isolierung Height without insulation Hauteur sans isolation Altezza senza isolamento	mm	1640	1710	2040	2010	2170	2370
Ø ohne Isolierung without insulation sans isolation senza isolamento	mm	700	790	790	950	1000	1100
Kippmass Tilted dimension Cote de basculement Altezza in raddrizzamento	mm	1690	1770	2100	2080	2250	2450
Einbringmass Delivery dimensions Cote de mise en place Ingombro	mm	730	800	800	950	1000	1100
Betriebsdruck Heizung Heater operating pressure Pression de service du chauffage Pressione d'esercizio riscaldamento	bar	3	3	3	3	3	3
Prüfdruck Heizung Heating test pressure Pression test du chauffage Pressione di collaudo riscaldamento	bar	4.5	4.5	4.5	4.5	4.5	4.5
Betriebsdruck Wasser Water operating pressure Pression de service de l'eau Pressione d'esercizio acqua	bar	6	6	6	6	6	6
Prüfdruck Wasser Water test pressure Pression test de l'eau Pressione di collaudo acqua	bar	12	12	12	12	12	12
max. Betriebstemperatur max. operating temperature Temp. de service max. Temperatura max. d'esercizio	°C	95	95	95	95	95	95
Gewicht Weight Poids Peso	kg	120	135	149	227	247	301
Art.Nr. 200205... Part no. Réf. Art.n.		0600	0800	1000	1250	1500	2000
Isolierung Insulation Isolation Isolamento	EU	TopShell 100				TopShell 130	TopShell 100
Wärmeverlust Heat losses Pertesthermiques Perdita di calore	kWh/24h	2.89	3.12	3.38	3.82	4.0	-
	W	121	130	141	160	167	-
ErP-Klasse ErP class Classe ErP Classe ErP		C	C	C	C	C	-
Gewicht Weight Poids Peso	kg	18	23	30	35	38	45
Art.Nr. 300113... Part no. Réf. Art.n.		0601	0801	1001	1251	1502	2001
Isolierung Insulation Isolation Isolamento	CH	TopShell 100				TopShell 130	TopShell 160
Art.Nr. 300113... Part no. Réf. Art.n.		0601	0801	1001	1251	1502	2003



Typ JH		600		800		1000		1250		1500		2000	
Heizfläche Edelstahlwellrohr Heating surface stainless steel corrugated pipe Surface de chauffe du tube ondulé en acier inoxydable Superficie riscaldante tubo ondulato	m ²	5.5		6.0		6.0		9.8		9.8		9.8	
Inhalt Edelstahlwellrohr Stainless steel corrugated pipe capacity Contenance du tube ondulé en acier inoxydable Contenuto tubo ondulato	l	28.1		31.0		31.0		51.0		51.0		51.0	
Puffertemperatur Buffer tank temperature Température du ballon Temperatura tampone	°C	60	80	60	80	60	80	60	80	60	80	60	80
Warmwasserdauerleistung Hot water continuous output Régime continu eau chaude Potenza continua acqua calda 10°C / 45°C / 80°C	l / min	7.2	11.6	7.8	12.0	7.8	12.0	13.5	22.6	13.5	22.6	13.5	22.6
max. Warmwasserdauerleistung Max. hot water continuous output Régime continu maxi eau chaude Potenza continua acqua calda max.	kW	18	31	20	34	20	34	32	55	32	55	32	55

Frischwasserspeicher
Fresh water storage tank
Ballon d'eau fraiche
Accumulatori d'acqua dolce
JH 600 – 2000

600 – 2000

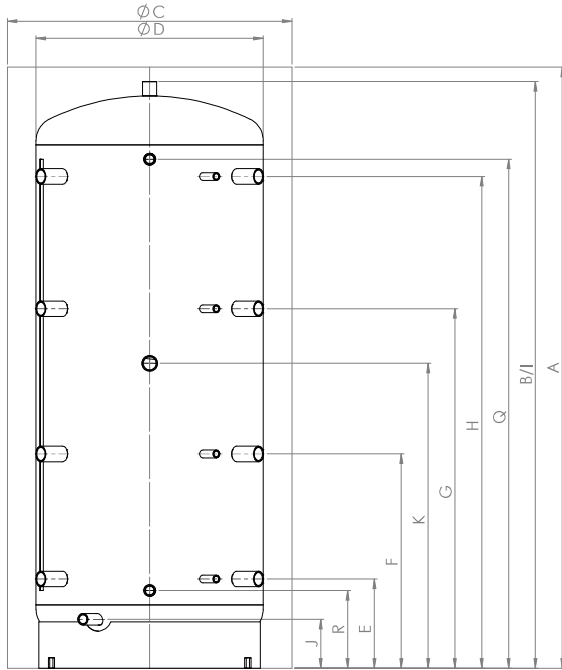



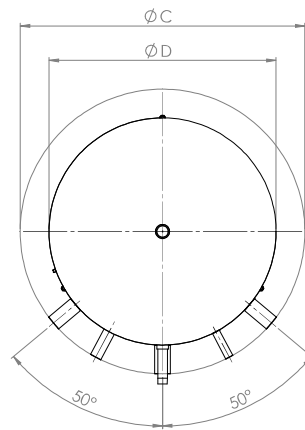









600 – 2000



600 – 2000



	Verwendung Usage Utilisation Uso	Dimension Dimension Dimension Dimensione	600	800	1000	1250	1500	2000
B	Höhe ohne Isolierung Height without insulation Hauteur sans isolation Altezza senza isolaento	mm	1640	1710	2040	2010	2170	2370
D	Ø ohne Isolierung without insulation sans isolation senza isolaento	mm	700	790	790	950	1000	1100
E	Anschluss 1 Connection Raccord Collegamento	 - mm	230	260	310	310	380	320
		G"	1 ½"	1 ½"	1 ½"	1 ½"	1 ½"	1 ½"
		 - G"	½"	½"	½"	½"	½"	½"
F	Anschluss 2 Connection Raccord Collegamento	 - mm	610	630	745	745	825	900
		G"	1 ½"	1 ½"	1 ½"	1 ½"	1 ½"	1 ½"
		 - G"	½"	½"	½"	½"	½"	½"
G	Anschluss 3 Connection Raccord Collegamento	 - mm	990	1030	1250	1250	1350	1490
		G"	1 ½"	1 ½"	1 ½"	1 ½"	1 ½"	1 ½"
		 - G"	½"	½"	½"	½"	½"	½"
H	Anschluss 4 Connection Raccord Collegamento	 - mm	1380	1430	1710	1710	1760	2020
		G"	1 ½"	1 ½"	1 ½"	1 ½"	1 ½"	1 ½"
		 - G"	½"	½"	½"	½"	½"	½"
I	Anschluss oben Connection above Raccord du haut Collegamento superiore	 - mm	1640	1710	2040	2010	2170	2370
		G"	1 ¼"	1 ¼"	1 ¼"	1 ¼"	1 ¼"	1 ¼"
J	Anschluss unten Connection below Raccord du bas Collegamento inferiore	 - mm	145	170	170	190	235	220
		G"	1"	1"	1"	1"	1"	1"
K	Elektroheizung zum Einschrauben* Screw-in Immersion heater* Résistances à visser* Resistenza elettrica da avvitare*	 - mm	850	915	1060	1060	1350	1315
		G"	1 ½"	1 ½"	1 ½"	1 ½"	1 ½"	1 ½"
Q	Edelstahlwellrohr Warmwasser Hot water stainless steel corrugated pipe Tube ondulé en acier inoxydable eau chaude Scambiatore di calore con tubo ondulato in acciaio inossidabile	 - mm	1380	1450	1770	1680	1835	1805
		G" - Aussengewinde External thread Filet extérieur Filettatura esterna	1"	1"	1"	1"	1"	1"
R	Edelstahlwellrohr Kaltwasser Cold water stainless steel corrugated pipe Tube ondulé en acier inoxydable eau froide Tubo ondulato acqua fredda	 - mm	230	260	270	310	335	305
		G" - Aussengewinde External thread Filet extérieur Filettatura esterna	1"	1"	1"	1"	1"	1"

*Einbaumöglichkeit: 1 x Elektroheizung zum Einschrauben
Installation option: 1 x Screw-in Immersion heater | Option d'installation: 1 x Résistances à visser | Opzione di installazione: 1 x Resistenza elettrica da avvitare



Höhe
Height | Hauteur | Altezza



Fühler
Sensor | Sonde | Sensore